

LEACHATE DISTRIBUTION AND ASSESSMENT OF GROUNDWATER QUALITY: A CASE STUDY OF RAWA KUCING LANDFILL, TANGERANG

Ika Wahyu Utami¹, Muhammad Najih², Larasati Rizky Putri³, dan Bambang Cholis Suudi⁴

¹ Teknik Industri, Universitas Trisakti, Jl. Kyai Tapa No.1, RT.6/RW.16, Tomang, Kec. Grogol petamburan, Kota Jakarta Barat, Daerah Khusus Ibukota Jakarta 11440, Indonesia,

ika.wahyu@trisakti.ac.id

² Teknik Informatika, Universitas Trisakti, Jl. Kyai Tapa No.1, RT.6/RW.16, Tomang, Kec. Grogol petamburan, Kota Jakarta Barat, Daerah Khusus Ibukota Jakarta 11440, Indonesia,

najihmuh@trisakti.ac.id

³ Teknik Mesin, Universitas Trisakti, Jl. Kyai Tapa No.1, RT.6/RW.16, Tomang, Kec. Grogol petamburan, Kota Jakarta Barat, Daerah Khusus Ibukota Jakarta 11440, Indonesia,

larasati.rizki@trisakti.ac.id

⁴ Teknik Industri, Universitas Trisakti, Jl. Kyai Tapa No.1, RT.6/RW.16, Tomang, Kec. Grogol petamburan, Kota Jakarta Barat, Daerah Khusus Ibukota Jakarta 11440, Indonesia,

bambangcholis@trisakti.ac.id

DOI : <https://doi.org/10.21107/pamator.v17i1.22650>

Manuscript received 12nd October 2023 , Revised 10th March 2024, Published 25th March 2024

Abstract

The self-potential (SP) method investigated leachate distribution near Rawa Kucing. Rawa Kucing is the main landfill in Tangerang that burned *almost* the entire area. A total of 78 SP data points were scattered throughout the study area. The SP values range from -20 to 16 millivolts, dominated by negative values attributed to electrokinetic processes. The results suggest that a highly conductive zone in the study area may have been caused by high contamination from leachate. The possible direction of leachate flow is towards the Cisadane stream, located west of the landfill. On the other hand, a quantitative interpretation of SP was conducted for two profiles, AA' and BB'. The result shows that the vertical spreading of leachate was found at a depth of h 6,59 and 3,53 meters and H 8,10 and 4,34 meters for AA' and BB', respectively, with an angle of 28,81°. Additionally, groundwater samples were collected from four sites near the landfill to assess groundwater quality using physical and chemical analysis. Based on the Indonesian Ministry of Health Regulation, most parameters indicated low contamination. Statistical analysis revealed that the groundwater near the landfill was worthy of consumption. Based on the results, rainfall during the study significantly reduced the concentrations of contaminants in leachate due to dilution.

Keywords: Landfill, Contamination, Pollutant indicators, Self-potential, Groundwater quality

© Authors: This is an Open Access Research distributed under the term of the Creative Commons Attribution-ShareAlike 4.0 International License (CC BY-SA 4.0) (<https://creativecommons.org/licenses/by-sa/4.0/>), which allows re-distribution and re-use of a licensed work on the conditions that the creator is appropriately credited and that any derivative work is made available under "the same, similar or a compatible license."

INTRODUCTION

Rawa Kucing landfill is the main landfill in Tangerang that implements an open dumping system in its waste management. Open dumping refers to a land disposal site at which solid wastes are disposed of in a manner that does not protect the environment, are susceptible to open burning, and are exposed to the elements, vectors, and scavengers.¹ Open dumping causes a negative impact due to leachate mismanagement and uncontrolled flows. Some research showed soil and groundwater contamination due to the presence of leachate.^{2,3,4} Landfill leachate has been one of the major environmental concerns because of its ability to contaminate groundwater aquifers. Depending on the topography, hydrology condition, and the rock type within the locality, leachates can travel several meters of vertical and horizontal distance.

A study on landfill-derived leachate is essential for assessing the subsurface properties changes and the environmental impact. To determine the presence of leachate, this research carried out a self-potential survey within the study area. Self-potential (SP) is a geophysical method widely used for investigating leachate movement and landfill evaluation since it is affordable, efficient, and simple.⁵ The SP method is based on measurements of naturally occurring electric potentials between two electrodes placed on the earth's surface.⁶ Some researchers have used self-potential measurements for detecting and quantifying contaminants in groundwater.^{7,8,9,10}

The local community's dependence on groundwater is very high, observed near Rawa

¹ M Yazdani and others, 'Municipal Solid Waste Open Dumping, Implication for Land Degradation', *Solid Earth Discussions*, 7 (2015), 1097–1118 <<https://doi.org/10.5194/sed-7-1097-2015>>.

² T. Janani, K. Prasanna, and R. Annadurai, 'Impact of Solid Waste Dumping in Pallavaram Dumping Site, India', in *AIP Conference Proceedings*, 2019, MMCXII, 020145–1–020145–49 <<https://doi.org/10.1063/1.5112330>>.

³ Henry Olawale Sawyerr and others, 'Impact of Dumpsites on the Quality of Soil and Groundwater in Satellite Towns of the Federal Capital Territory, Abuja, Nigeria', *Journal of Health and Pollution*, 7.14 (2017), 15–22 <<https://doi.org/10.5696/2156-9614-7.14.15>>.

⁴ Nitin Kamboj and Mohrana Choudhary, 'Impact of Solid Waste Disposal on Ground Water Quality near Gazipur Dumping Site, Delhi, India', *Journal of Applied and Natural Science*, 5.2 (2013), 306–12 <<https://doi.org/10.31018/jans.v5i2.322>>.

⁵ John M. Reynolds and others, *Introduction to Applied and Environmental Geophysics*, 2nd edn (John Wiley & Sons, Ltd., 2011).

⁶ W. M. Telford, L. P. Geldart, and R. E. Sheriff, *Applied Geophysics*, 1st edn (New York: Cambridge University Press, 1990) <<https://doi.org/10.1017/cbo9781139167932>>.

⁷ N. V. Giang and others, 'Landfill Leachate Assessment by Hydrological and Geophysical Data: Case Study NamSon, Hanoi, Vietnam', *Journal of Material Cycles and Waste Management*, 20.3 (2018), 1648–62 <<https://doi.org/10.1007/s10163-018-0732-7>>.

⁸ Andri Wasis Handoko, D Darsono, and D Darmanto, 'Aplikasi Metode Self Potential Untuk Pemetaan Sebaran Lindi Di Wilayah Tempat Pembuangan Akhir (TPA) Putri Cempo Surakarta', *Indonesian Journal of Applied Physics*, 6.1 (2016), 13–22 <<https://doi.org/10.13057/ijap.v6i01.1792>>.

⁹ M. Arisalwadi and Rahmania, 'Mapping Leachate Distribution Based on the Self-Potential Method in Manggar Landfill, Balikpapan Indonesia', in *Journal of Physics: Conference Series* (Palu: IOP Publishing, 2021), MDCCCLXIII, 012013 <<https://doi.org/10.1088/1742-6596/1763/1/012013>>.

¹⁰ Meryem Touzani and others, 'Mapping the Pollution Plume Using the Self-Potential Geophysical Method: Case of Oum Azza Landfill, Rabat, Morocco', *Water (Switzerland)*, 13.7 (2021), 961 <<https://doi.org/10.3390/w13070961>>.

Kucing, even though shallow aquifers near the landfill are vulnerable to leachate contamination. Many studies have been conducted to assess the contamination of groundwater quality due to landfill contamination.^{11,12} The impact of landfill leachate on groundwater quality during this study was estimated using physical and chemical analysis. On the other hand, the groundwater quality assessment was carried out by applying the Sturges rule. The Sturges rule determines the number of classes when the total number of observations is given.¹³ Sturges rule is widely applied in research on determining class intervals for data classification.^{14,15} By applying the Sturges method, the water quality classification class in the study area can be determined whether it is feasible or not for consumption.

The study area is located within the Neglasari district in the northern part of Tangerang. Figure 1 shows the study area map with geological data. Rawa Kucing landfill is located at an average elevation of 14 m above sea level and outstretched with a gentle slope of 0 – 3%. Based on the geological data, the Rawa Kucing landfill is part of the Jakarta Basin, composed of alluvial deposits. Alluvial deposits in the study area typically consist of well-sorted clay, silt, sand, and gravel. The study area is underlain by a quaternary rock consisting of Banten tuff, claystone tuff, breccia, and tuffaceous sandstone.¹⁶ Cisadane is the only river leading in the study area utilized as a Tangerang domestic water source. The climate is humid, with typical temperatures between 22,6°C and 37,0°C. The maximum rain occurred during January, February, March, and December.

¹¹ Anna Podlasek and others, 'Monitoring and Assessment of Groundwater Quality at Landfill Sites: Selected Case Studies of Poland and the Czech Republic', *Sustainability (Switzerland)*, 13.14 (2021), 7769 <<https://doi.org/10.3390/su13147769>>.

¹² Izabela A. Talalaj, 'Assessment of Groundwater Quality near the Landfill Site Using the Modified Water Quality Index', *Environmental Monitoring and Assessment*, 186.6 (2014), 3673–83 <<https://doi.org/10.1007/s10661-014-3649-1>>.

¹³ David W. Scott, 'Sturges' Rule', *Wiley Interdisciplinary Reviews: Computational Statistics*, 1.3 (2009), 303–6 <<https://doi.org/10.1002/wics.35>>.

¹⁴ Hamzar Hamzar, Suprpta Suprpta, and Amal Amal, 'Analisis Kualitas Air Tanah Dangkal Untuk Keperluan Air Minum Di Kelurahan Bontonompo Kecamatan Bontonompo Kabupaten Gowa', *Jurnal Environmental Science*, 3.2 (2021), 150–59 <<https://doi.org/10.35580/jes.v3i2.20048>>.

¹⁵ Maryo Rifaldo Luhukay, Rieneke L E Sela, and Papia J C Franklin, 'Analisis Kesesuaian Penggunaan Lahan Permukiman Berbasis (Sig) Sistem Informasi Geografi Di Kecamatan Mapanget Kota Manado', *Spasial*, 6.2 (2019), 271–81 <<https://doi.org/10.35793/sp.v6i2.25309>>.

¹⁶ Mohamad Sapari Dwi Hadian and others, 'Sebaran Akuifer Dan Pola Aliran Air Tanah Di Kecamatan Batuceper Dan Kecamatan Benda Kota Tangerang, Propinsi Banten', *Indonesian Journal on Geoscience*, 1.3 (2006), 115–28 <<https://doi.org/10.17014/ijog.vol1no3.20061>>.

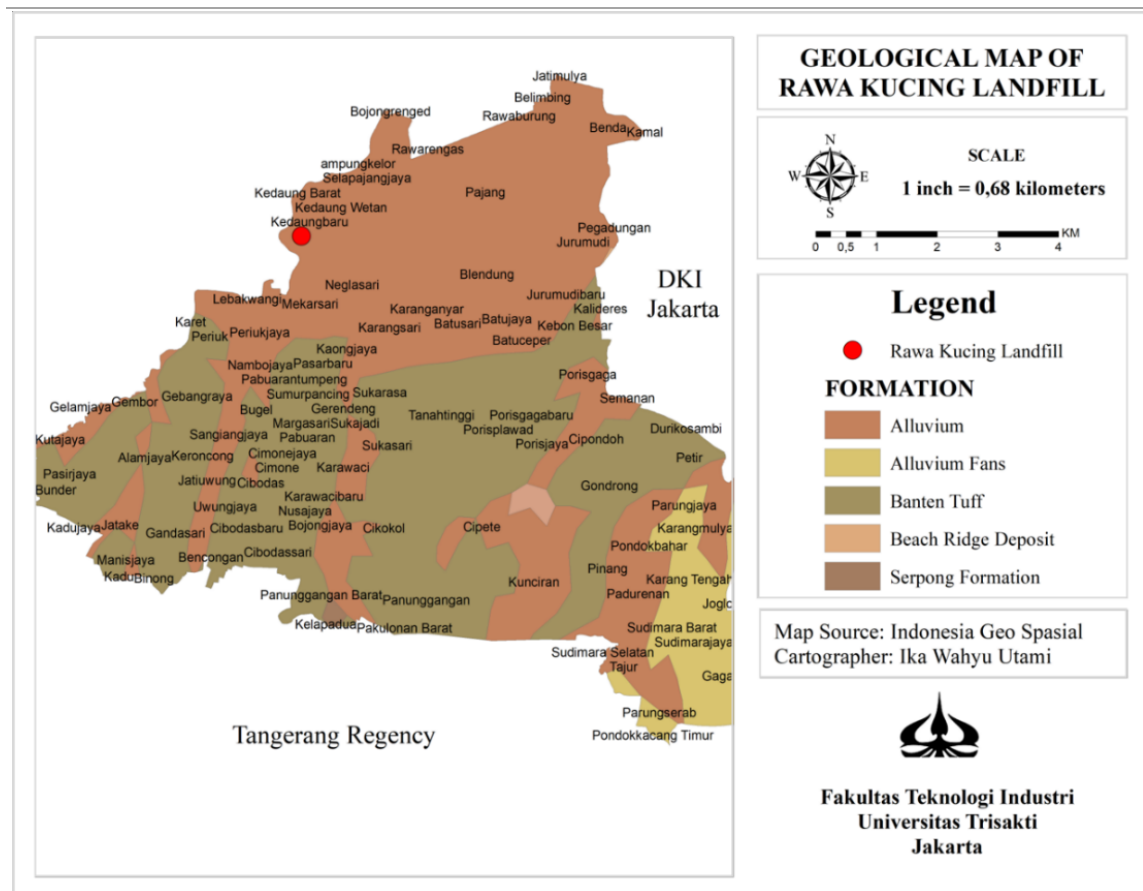

Figure 1. Geology map of the study area (Maps digitized from Indonesia Geo Spasial)

RESEARCH METHODS

SP acquisition occurred in the Rawa Kucing landfill along four arrays in January 2022. The required equipment includes a copper rod in a saturated copper sulfate solution in paired nonpolarizable electrodes, as shown in Figure 2, a global positioning system (GPS), a rolling meter, an electrical wire, and a voltmeter with high input impedance (Sanwa Cd800a). The fixed-base method was used for SP measurement since this method is more accurate in detecting small anomalies than the leapfrog method. The fixed-base method keeps a single electrode (base station) in one place without moving it, and the other (rover electrode) is moving along the measurement lines, as shown in Figure 3.

The base station electrode acts as the reference point for all other measurements. An electrode spacing of 2 m was chosen for this study, with 78 data points from all measurement paths. Electrodes calibration was conducted before the SP measurement to obtain better acquisition data. The calibration was carried out by measuring the voltage between the two electrodes set on the ground at an approximately 10 cm distance. The potential difference values measured during calibration must be smaller or equal to 2 millivolts.¹⁷ Data retrieval on the SP measurement includes the potential value at each measurement point and the potential value for data correction. Data correction includes the base daily variation correction, daily correction, and closure correction. Measuring

¹⁷ Telford, Geldart, and Sheriff.

the potential value of the base was done by repeatedly measuring the potential value at the same point with time intervals every 2 minutes.

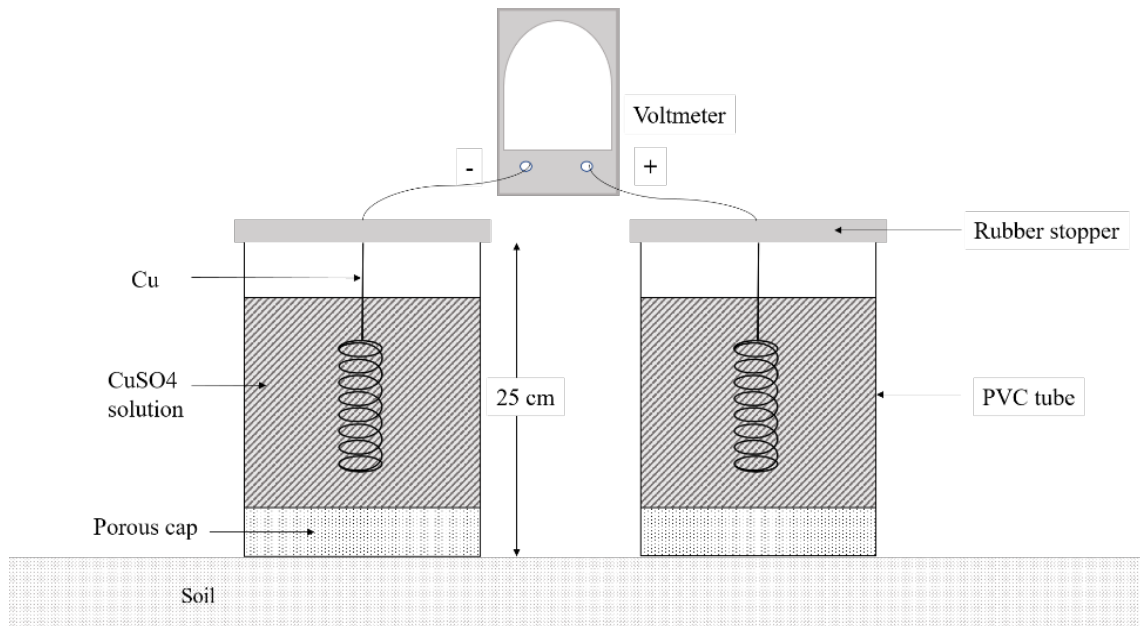

Figure 2. Schematic diagram of nonpolarizable electrodes used in this study

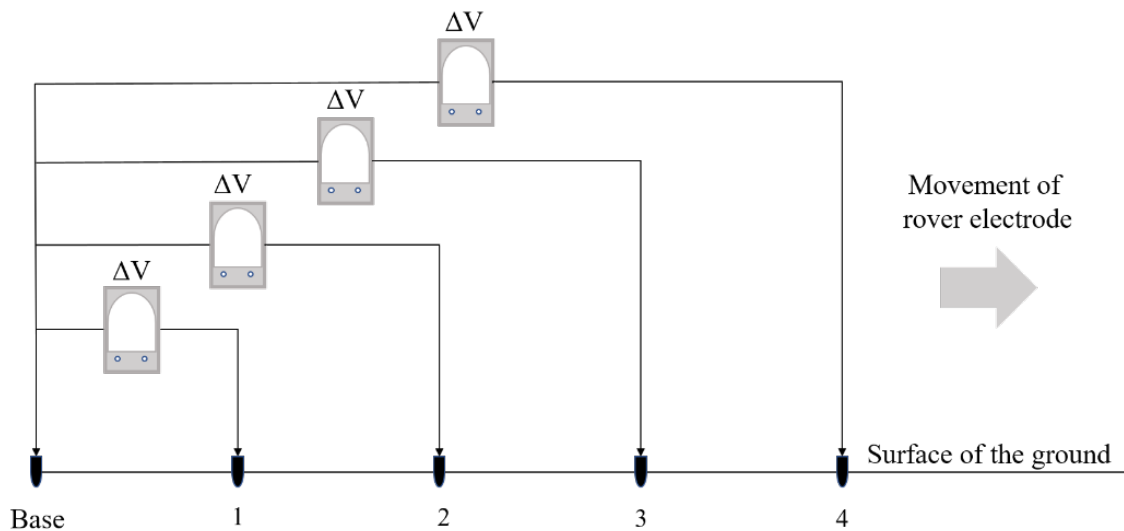

Figure 3. SP method gradient array configuration

In addition to SP measurements, groundwater quality testing around the landfill area was also carried out in this study. Four groundwater samples were acquired from dug wells located 100 m – 2 km from the landfill with a dug well depth of about 10 m. Samples were carried out in the morning from 6 AM – 8 AM. The samples were scrutinized to interpret water quality's physics and chemistry parameters. Samples were obtained in 1,5L of polyethylene bottles. The acquired samples were subjected to evaluating water quality criteria such as color, odor, taste, turbidity, electrical conductivity (EC), pH, total dissolved solids (TDS), organic matters, total alkalinity, CO₂, and major cations-anions.

pH, EC, and TDS were taken by in situ measurements with a portable water quality instrument, while the odor and taste measurements were done by an organoleptic method.

The determination of color was done by comparing a sample of water in a colored solution similar to natural water whose concentration is known. Heavy metals (Fe and Mn), nitrate, and nitrite were analyzed using a spectrophotometry method concurrently. On the other hand, the water hardness, CO₂, Ca²⁺, and Mg²⁺ were examined with titration procedures. The sulfate ions were established using the photometer. Chloride ions were determined using a simple precipitation method, the Mohr method of argentometric titration. A quantitative analysis was carried out using the permanganometric titration method to determine the levels of organic matter in the samples.

Data Processing

The corrected SP data processing was carried out using *Ms. Excel*, and the result was performed by *Surfer 20*. The result obtained was an isopotential contour map as an SP data response. Furthermore, a slicing of one cross-section was performed to analyze the source of the SP anomaly. Thus, the SP anomaly profile corresponding to distances was obtained. Furthermore, the assessment of the study area's physical and chemical groundwater quality was used to analyze the groundwater quality index.

Data Interpretation

Isopotential contours that describe leachate distribution as a subsurface characteristic around the Rawa Kucing landfill were interpreted qualitatively and quantitatively. The qualitative interpretation of the isopotential contours was carried out to analyze the leachate distribution, while the quantitative understanding was carried out to determine the SP anomaly parameters. Determination of the anomaly parameters was carried out by calculating the inclined plate model developed by Rao & Babu (1983).¹⁸ The inclined plate is considered a source of SP anomaly, which is in-depth from the top end (h) to the bottom end (H) with an anomaly dip of θ (Equation (1) to (4)). $x_{1/2}$ is the distance between $\frac{1}{2} V_{\max}$ and V_{\min} , x is the symmetrical distance, i.e., the distance from the origin to the point that has the same amplitude but different signs, x_{\max} is the distance from the origin point to the point that has the maximum voltage. At the same time, x_{\min} is the distance from the origin to the point with the minimum voltage.

$$h = (|x_{\max} \cdot x_{\min}|)^{\frac{1}{2}} \quad (1)$$

$$a = \frac{x - h^2}{2x_{1/2}} \quad (2)$$

$$H = (x^2 - a^2)^{\frac{1}{2}} \quad (3)$$

$$\theta = \tan^{-1} \left(\frac{H - h}{a} \right) \quad (4)$$

The water quality assessment conducted in this study refers to the Regulation of the Indonesian Minister of Health Regulation No. 492/10/2010, which represents the standards for the quality of clean water and drinking water.¹⁹ On the other hand, the Sturges rule was applied to determine the classification of the water quality index in the study area. In this study, water quality can be classified into two interval classes: feasible

¹⁸ D. Atchuta Rao and H. V. Ram Babu, 'Quantitative Interpretation of Self-Potential Anomalies Due to Two-Dimensional Sheet-like Bodies.', *Geophysics*, 48.12 (1983), 1659–64 <https://doi.org/10.1190/1.1441446>.

¹⁹ Kemenkes RI, 'Peraturan Menteri Kesehatan Nomor 492/IV/2010 Tentang Persyaratan Kualitas Air Minum' (Menteri Kesehatan Republik Indonesia, 2010).

and not for consumption. Suppose the physical and chemical indicator of water quality result is above the maximum allowable limit. In that case, the score is 1 (considered not feasible for consumption), while if the indicator result is below the permitted standard, then the score is 2, deemed feasible for consumption. The calculation in determining the classification of the water quality index is by scoring the feasibility of groundwater for consumption based on the Sturges rule defined below (Equation (5)).²⁰

$$ic = \frac{a - b}{k} \quad (5)$$

Where ic is the interval class, a is the maximum score, b is the minimum score, and k is the class total. The maximum and minimum scores can be determined using the total number of parameters tested (n), as shown in Equation (6).

$$a = n \times 2; b = n \times 1 \quad (6)$$

RESULT AND DISCUSSION

Leachate Distribution

The observed SP anomalies are shown in Figure 4 using a color scale. Based on the results, the SP anomalies show the dominance of negative values ranging from -20 to 16 millivolts. The factor considered responsible for SP anomalies in this study is based on the table of SP anomalies, and their geological structure is a fluid movement. The landfill environment is highly conductive since high heavy metal concentrations characterize leachate. This is indicated by the low potential value, which is numerically negative (low). The negative values obtained are in confirmation with the findings of other researchers.^{21,22} This study's very low SP values are interpreted as a shallow leachate accumulation zone as attested with green to purple color, with a lower SP value than the surrounding area that is not contaminated by leachate.

An electrokinetic potential (Ek) may be the cause of the anomalies. An electrokinetic potential will emerge as an electrolyte flows through a porous medium due to the difference in hydrostatic pressure. According to Helmholtz's law (Equation 7), the electric current flow is related to the hydraulic gradient and a quantity known as the electro-filtration coupling coefficient, which takes into account the physical and electrical properties of the electrolyte and the network through the medium through which the electrolyte has passed.²³

$$\delta V = \frac{\varepsilon \mu C_E \delta P}{4\pi\eta} \quad (7)$$

With δV is the electric potential difference, ε is the dielectric constant, μ is electrolyte resistivity, C_E is the electrofiltration coupling coefficient, δP is the hydrostatic

²⁰ Luhukay, Sela, and Franklin.

²¹ Giang and others.

²² Handoko, Darsono, and Darmanto.

²³ Reynolds and others.

pressure difference, and η dynamic viscosity of the electrolyte. Equation (7) shows that the electric current will always be perpendicular to the equipotential plane. Therefore, the fluid flow is in the direction of the electric current. Based on conventional electrical theory, electric current will flow from a point with a high potential (positive pole) to a point with a low potential (negative pole). On the other hand, Darcy's law, which acts as the fundamental law for fluid flows in porous media, states that the fluid flow direction is opposite to the SP gradient direction, where the fluid flows from a location with a high SP value to the location with low SP value.²⁴

Figure 5 shows the study area's fluid flow pattern of leachate distribution. The fluid flow mostly leads to the northwest-west-southwest of the Rawa Kucing landfill. The fluid flow forms a continuous pattern from the direction of the landfill and accumulates in the western area of the landfill. The electrokinetic effect causes the accumulated leachate as a negative potential due to the influence of gravity, in which the leachate flow moves from a higher to a lower altitude. Besides that, Darcy's law states that fluid flows from a location with a higher SP to a lower SP location. The contaminant does propagate towards the west according to the regional hydrogeological flow, where the contaminated water will join the Cisadane River system. The study from Wahyuni et al. (2017) also mentions that the Cisadane River near the Rawa Kucing landfill may cause some leachate flow into the river.²⁵

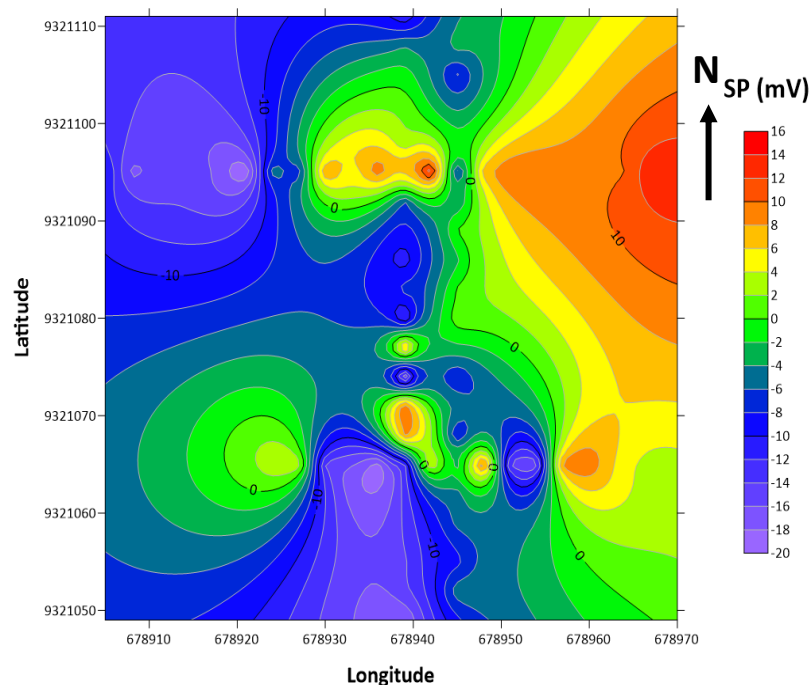

Figure 4. Isopotential contour map of the study area

²⁴ Neng E. Jubaedah and Wahyudi W. Parnadi, 'Study of Fluid Flow Movement by Using Self Potential Data', in *IOP Conference Series: Earth and Environmental Science* (Bandung: IOP Publishing, 2021), DCCCLXXIII, 012082 <<https://doi.org/10.1088/1755-1315/873/1/012082>>.

²⁵ Wahyuni Wahyuni, Supriyono Eko Wardoyo, and Ridha Arizal, 'Kualitas Air Sumur Masyarakat Di Sekitar Tempat Pembuangan Akhir Sampah (TPAS) Rawa Kucing Kota Tangerang', *Jurnal Sains Natural Universitas Nusa Bangsa*, 7.2 (2017), 68–82 <<https://doi.org/10.31938/jsn.v7i2.256>>.

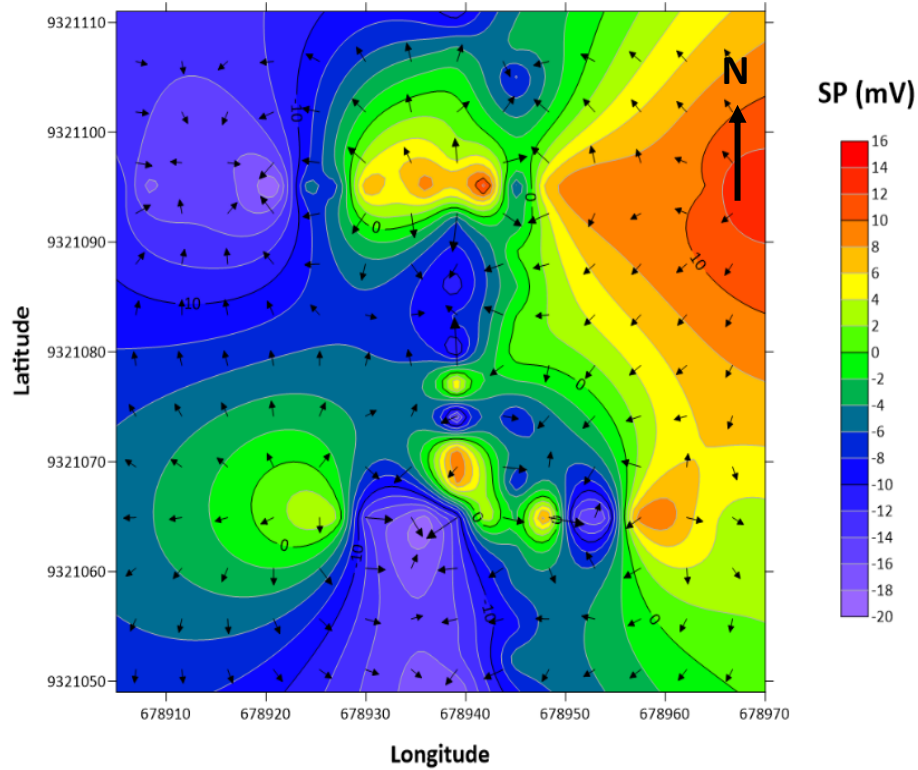

Figure 5. Fluid flow patterns in the study area

Anomaly Parameters

This study conducted a quantitative interpretation by selecting two cross-section profiles to obtain the anomaly parameters. The first profile (AA') is a slicing that leads from northwest to southeast, as shown in Figure 6a, while the second profile (BB') is a path that leads from west to east, as shown in Figure 6b. Two profile curves were constructed to represent the potential anomalies for the distance of each electrode. The profile curves of the AA' and BB' profiles are shown in Figure 7.

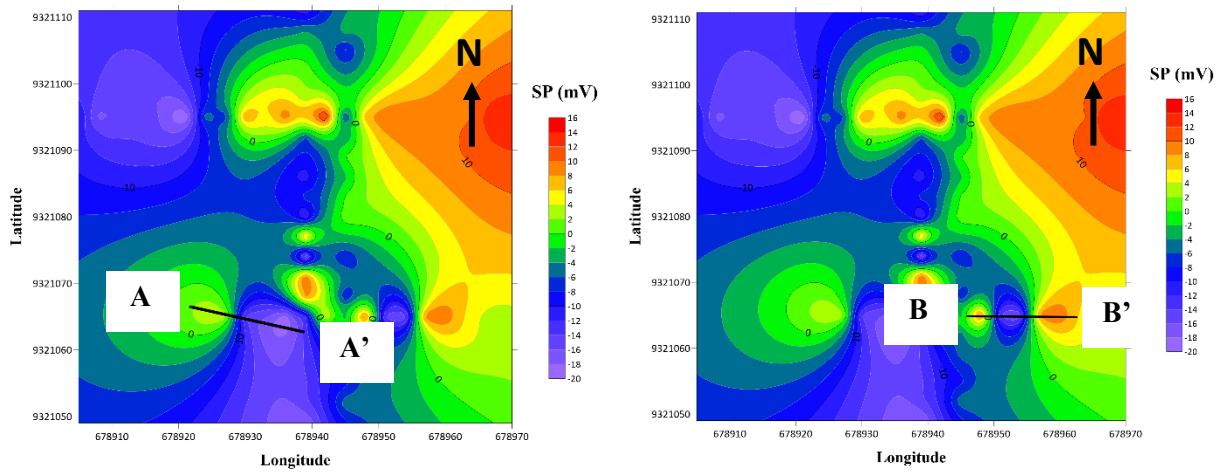

Figure 6. The first profile (AA')

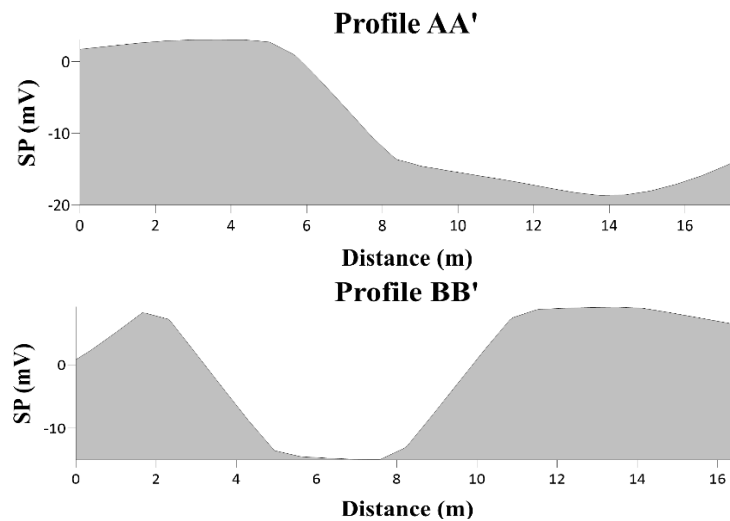

Figure 7. The profile curve of AA' and BB's profiles

Based on the digitization SP values, the AA' profile ranges from -18,63 mV to 3,03 mV, ranging from 0 meters to 17,31 meters. From the digitization of BB's profile, the SP value ranges from -14,90 mV to 8,32 mV with a distance range from 0 meters to 16,51 meters. The AA' and BB' profile curves tend to show a vertical and steep slope from positive to negative value. It can be indicated that the cross-section lines pass through the leachate accumulation zone in the study area.

The leachate vertical distribution around the study area was determined by SP anomaly parameters calculation using the inclined plate modeling by Rao & Babu (1983) for the AA' and BB' profiles.²⁶ The result from the calculation shows that the leachate accumulation in the AA' profile was located at the upper edges (h) of 6,59 meters and the lower edges (H) of 8,10 meters with an angle (θ) of $28,81^\circ$. In comparison, the SP anomaly in BB's profile was located at the upper edges (h) of 3,53 meters and the lower edges (H) of 4,34 meters with an angle (θ) of $28,81^\circ$.

²⁶ Rao and Babu.

Comparing the AA' and BB' profiles, the depth of leachate accumulation in the AA' profile located on the west is deeper than the BB' profile. Thus, it can be interpreted that the direction of the leachate flow comes from east to west through the subsurface rock's pores and follows the elevation changes where there is a Cisadane stream in the west of Rawa Kucing landfill.

The results of the SP measurement obtained in this study will then be compared with a rock lithology correlation table with the self-potential value as a reference for determining the subsurface conditions of the research area, as shown in Table 1. The SP values obtained in this study ranged from -20 to 16 mV. Based on Table 1, the SP values obtained in the measurement results are per the geological data of the research area. Based on the geological study of the research area, the rocks that cover the city of Tangerang are composed of tuff, claystone tuff, breccia, and tuffaceous sandstone, which is overlain by alluvium deposits.

Table 1. Potential value of rock based on lithology

No.	Lithology	Self-potential (mV)
1	Tuffaceous sand	14 – 34
2	Tuffaceous	12 – 14
3	Scrap material	5 – 13
4	Tuffaceous breccia	4 – 5
5	Breccia	1 – 3

Sumber: Subagio et al. (2020)²⁷

Groundwater Quality Assessment

The groundwater quality assessment includes the physical and chemical parameters, which refer to the Regulation of the Indonesian Minister of Health No. 492/IV/2010.²⁸ This assessment aims to determine the quality of the aquifers around the landfill by comparing the quality standards for clean water and drinking water. Table 2 is the laboratory test result based on physical and chemical parameters near the landfill.

Table 2. Water quality assessment result for the study area

Parameter	Result				Unit
	Sample 1	Sample 2	Sample 3	Sample 4	
Physics Parameter					
Color	7,0	3,0	3,0	4,0	Pt-co
Odor	Odorless	Odorless	Odorless	Odorless	-

²⁷ Budy Santoso and others, 'Investigasi Pendugaan Gerakan Tanah Menggunakan Metode Electrical Resistivity Tomography Dan Self Potential Di Daerah Pasanggrahan Baru, Sumedang Selatan', *Jurnal Geologi Dan Sumberdaya Mineral*, 21.1 (2020), 33-44 <<https://doi.org/10.33332/jgsm.geologi.v21i1.497>>.

²⁸ Kemenkes RI.

Taste	Tasteless	Tasteless	Tasteless	Tasteless	-
Turbidity	62,3	0,0	0,39	0,90	NTU
Electrical Conductivity	901	934	887	744	$\mu\text{S/cm}$
Chemistry Parameter					
pH	7,3	7,2	7,4	7,7	-
TDS	450	467	442	372	mg/L
Organic Substances	19,02	10,59	21,83	16,21	mg/L
CO ₂	0,0	0,0	0,0	0,0	CO ₂
Alkalinity	336	275,2	236,8	268,8	mg/L
Water Hardness	372	396	264	288	mg/L
Calcium (Ca ²⁺)	76,8	83,2	52,8	76,8	mg/L
Magnesium (Mg ²⁺)	43,74	45,68	32,08	23,33	mg/L
Chloride (Cl ⁻)	85,46	101,16	48,84	123,83	mg/L
Iron (Fe)	3,48	<0,01	<0,01	0,33	mg/L
Manganese (Mn)	0,01	0,01	<0,01	<0,01	mg/L
Nitrate (NO ₃ ⁻)	0,05	0,08	0,06	0,05	mg/L
Nitrite (NO ₂ ⁻)	<0,01	<0,01	<0,01	<0,01	mg/L
Sulfate (SO ₄ ²⁻)	42,75	57,25	56,75	51	mg/L

Turbidity

Turbidity is considered a good measure of the quality of water. Turbidity refers to how clear a liquid is. High turbidity means the liquid is not very clear; low turbidity means the liquid is clearer. Turbidity is often used to test water quality heuristically. Greater turbidity typically implies lower quality. Based on laboratory testing, sample 1 has a turbidity level that exceeds the threshold of 62,3 NTU since it appeared to have a brownish color. According to Gafur et al. (2017), this can be caused by solid particles being suspended in water bodies since the research was carried out during the rainy season.²⁹ Furthermore, sample 1, which has a turbidity level above the threshold, is a sample taken from a location close to the Cisadane stream with a lower elevation than the surrounding area. It can be interpreted that rainwater flows from a higher to a lower point. Thus, solid particles will accumulate and cloud the stored water body.

Electrical Conductivity (EC)

Electrical conductivity (EC) is the ability of water to conduct an electric current. The conductivity for the four samples in this study is measured by a conduct meter electrode

²⁹ Abdul Gafur, Andi Darma Kartini, and Rahman Rahman, 'Studi Kualitas Fisik Kimia Dan Biologis Pada Air Minum Dalam Kemasan Berbagai Merek Yang Beredar Di Kota Makassar Tahun 2016', *HIGIENE: Jurnal Kesehatan Lingkungan*, 3.1 (2017), 37-46 <<https://www.academia.edu/download/88092641/234747925.pdf>>.

using a potassium chloride (KCl) solution at a temperature of 25⁰C. The laboratory tests showed that the EC value was in the range of 744 to 934 S/cm. The four samples did not meet the quality standards for drinking water since it should not be allowed to have the ability to conduct electricity. The EC value can be affected by the environmental conditions of the study area and the type of rock formation present.

The research area is composed of alluvial soil, with one of the sediment compositions consisting of sand. Sand is a type of rock that allows fluid entry into the rock pores. Allegedly, the sandstone pores in the study area are partially filled with fluids containing elements that can conduct electricity, such as metallic elements originating from the leachate of the Rawa Kucing landfill.

Water Hardness

Water hardness is a property of water due to two-valent metal ions (cations) such as Ca²⁺, Mg²⁺, Sr²⁺, Fe²⁺, and Mn²⁺, especially calcium (Ca) and magnesium (Mg). The measurement shows that the water hardness of four samples ranged from 264 to 396 mg/L, and sample 2 had the highest value of the hardness level. According to the Indonesian Minister of Health's Regulation No. 492/Menkes/Per/IV/2010, these results are allowable for the drinking water requirements.³⁰ Furthermore, the result will be compared with the water hardness classification from Peavy et al. (1985), as shown in Table 3.³¹

Table 3. Water hardness classification

No.	Water hardness Level (mg/L)	Classification
1	< 50	Soft
2	50 – 150	Medium hard
3	150 – 300	Hard
4	> 300	Very hard

This comparison aims to determine how much the hardness level is based on the class. Based on Table 3, it can be interpreted that all samples are classified as water that had a high hardness level. Although the samples were still below the Indonesian Minister of Health's Regulation threshold, the groundwater of the study area represented by the four samples was unsuitable for consumption. Consuming water that has a high hardness level will have an impact on health. The effect of hard water on health causes cardiovascular disease and urolithiasis.³²

Magnesium and Calcium

The results showed that magnesium and calcium content for four samples varied between 23,33 to 45,68 mg/L and 52,8 to 76,8 mg/L for magnesium and calcium, respectively. The highest content was found in sample 2, with 45,68 mg/L of magnesium

³⁰ Kemenkes RI.

³¹ Howard Peavy, *Environmental Engineering*, 7th edn (McGraw-Hill, 1987).

³² Ulfa Nurullita, Rahayu Astuti, and Mohammad Zaenal Arifin, 'Pengaruh Lama Kontak Karbon Aktif Sebagai Media Filter Terhadap Presentase Penurunan Kesadahan CaCO₃ Air Sumur Artetis', *Jurnal Kesehatan Masyarakat Indonesia*, 6.1 (2020), 48–56
<<https://doi.org/10.26714/jkmi.6.1.2010.%25p>>.

and 83,2 mg/L of calcium. These results indicate that the groundwater around the Rawa Kucing landfill still contains elements of magnesium and calcium, which are not allowed in clean water or drinking water according to the Indonesian Minister of Health's Regulation standard. From the hardness level of the four samples, the hardness level of sample 2 is the highest among the others. Therefore, it shows that magnesium and calcium content is related to the water hardness level.

Iron and Organic Substances

Iron is a chemical element that is commonly found in water. High iron concentrations in water bodies will be hazardous because iron is one of the most dangerous heavy metals. Water-containing iron is highly undesirable for domestic use since it can cause rust marks on clothes, porcelain, and other tools. Furthermore, a dissolved iron gives water a disagreeable metallic taste. The results showed that two samples had iron concentrations that exceeded the permissible limit of 0.3 mg/L per the Indonesian Minister of Health's Regulation standard. Sample 1 has an iron element of 3,48 mg/L, sample 4 has an iron concentration of 0,33 mg/L, while the other two well samples are <0,01 mg/L. This result is in line with the turbidity level of sample 1 water. Compared to the other three samples, the turbidity level of sample 1 is 62,3 NTU. Iron levels that exceed the threshold in sample 1 can cause the water to become turbid.

The four samples contained organic substances exceeding the predetermined threshold of 10 mg/L. Excessive organic substances in clean water are prohibited since they can cause unwanted colors, odors, and tastes. Organic substances may also be toxic directly or after combining with other substances. Organic substances in water can come from nature or human activities, i.e., from humic acid from rotting leaves and tree trunks, nitrogen compounds, and sulfuric compounds from decaying organisms. Human activities in their daily life include disposing of waste in feces, liquid waste, solid waste, and gas, both from household activities and other activities.

Based on the Indonesia Waste Management Information System data, more than 60 percent of the Rawa Kucing landfill waste is organic, with the dominant composition coming from food waste. The abundance of organic substances contained in the waste of the Rawa Kucing landfill will impact the aquifer system, especially if the content of the organic substances decomposes and mixes with rainwater to seep into the ground.

The Application of Sturges Rule for Water Quality Assessment

Sturges rule determines the desirable number of groups into which a distribution of observations should be classified. The data in Table 1 shows that the water quality can be classified as feasible or not for consumption. If it is below the standard, then the score is 2, while if it is above the standard, it is 1. Based on the results of the Sturges rule, the following table results from the calculation of the groundwater quality standard in the research area, as shown in Table 4.

Table 4. Water quality analysis for the study area

Parameter	Standards	Score				Total score*
		Sample 1	Sample 2	Sample 3	Sample 4	
Color	15	2	2	2	2	8

Odor	Odorless	2	2	2	2	8
Taste	Tasteless	2	2	2	2	8
Turbidity	5	1	2	2	2	7
Electrical Conductivity	-	1	1	1	1	6
pH	6,5 – 8,5	2	2	2	2	8
Total Dissolved Solids	500	2	2	2	2	8
Organic Substances	10	1	1	1	1	4
CO ₂	-	2	2	2	2	8
Alkalinity	500	2	2	2	2	8
Water Hardness	500	2	2	2	2	8
Calcium (Ca ²⁺)	-	1	1	1	1	8
Magnesium (Mg ²⁺)	-	1	1	1	1	8
Chloride (Cl ⁻)	250	2	2	2	2	8
Iron (Fe)	0,30	1	2	2	1	6
Manganese (Mn)	0,40	2	2	2	2	8
Nitrate (NO ₃ ⁻)	50,0	2	2	2	2	8
Nitrite (NO ₂ ⁻)	3,00	2	2	2	2	8
Sulfate (SO ₄ ²⁻)	250	2	2	2	2	8
Total		32	34	34	33	

By applying Equation (6) to the laboratory test data in this study, it obtained the highest score (max) was 38, and the lowest score (min) was 19. The determination of class interval was done by calculating Equation (5). For this study, we divided two classes for water quality assessment with their range, as shown in Table 5.

Table 5. Range of water quality class qualifications

Water Quality	Range
Feasible	$\geq (\max - ic + 1)$
Not feasible	$\leq (\max - ic)$

From the calculation, the interval class obtained was 10. Thus, the water quality class qualifications based on observation points can be divided into:

1. Not feasible for drinking water if the score obtained ≤ 28
2. Feasible for drinking water if the score obtained ≥ 29

The following table shows the analysis results of shallow groundwater quality analysis in the study area, as shown in Table 6.

Table 6. Feasibility classification of shallow groundwater quality in the study area

Samples	Score	
	Feasible for consumption (≥ 29)	Not Feasible for Consumption (≤ 28)
Sample 1	32	-
Sample 2	34	-
Sample 3	34	-
Sample 4	33	-
Notes	Meet the allowable standard	Doesn't meet the acceptable standard

Based on the groundwater quality classification results, all samples taken from four sample points around the Rawa Kucing landfill indicated that the groundwater was feasible for consumption. However, several parameters exceeded the allowable standards. This result must follow the research conducted by Wahyuni et al. (2017).³³ The result from Wahyuni et al. (2017) shows that almost all water quality parameters have a high level of contamination.³⁴ The timing of groundwater sample acquisition can cause these differences. The sample collection during dry and rainy seasons will produce different results. Since the study area is located in tropical countries and the research was conducted in January, where the intensity and duration of recorded rainfall were extremely high, the leachate parameters were observed to undergo a significant reduction. This results in agreement with the study of the effect of rainfall on the pollution potential of leachate on groundwater conducted by many researchers.³⁵³⁶³⁷ In months with frequent rains, leachate amounts increase, and the pollutants are diluted. Due to the dilution of the dissolved organic matter and inorganic minerals present in leachate concentration, the water quality in the study improved. Therefore, the groundwater was feasible for consumption.

CONCLUSION

This paper investigated the leachate distribution and groundwater quality in Rawa Kucing landfill, Tangerang, through the SP method and Sturges rule. Based on these

³³ Wahyuni, Wardoyo, and Arizal.

³⁴ Wahyuni, Wardoyo, and Arizal.

³⁵ Magdalena Daria Vaverková and others, 'Chemical Composition and Hazardous Effects of Leachate from the Active Municipal Solid Waste Landfill Surrounded by Farmlands', *Sustainability (Switzerland)*, 12.11 (2020), 4531 <<https://doi.org/10.3390/su12114531>>.

³⁶ Nur Fatin Dahlia Mat Salleh and Ku Halim Ku Hamid, 'Effect of Rainfall on Aged Landfill Leachate Constituents', in *BEIAC 2013 - 2013 IEEE Business Engineering and Industrial Applications Colloquium* (Langkawi, Malaysia: IEEE, 2013), pp. 257–61 <<https://doi.org/10.1109/BEIAC.2013.6560127>>.

³⁷ Sajjad Ahmad Siddiqi and others, 'Characterization and Pollution Potential of Leachate from Urban Landfills during Dry and Wet Periods in Arid Regions', *Water Supply*, 22.3 (2022), 3462–83 <<https://doi.org/10.2166/WS.2021.392>>.

results, several conclusions were obtained, including the results of SP measurements ranging from -20 to 2016 mV, which indicate that the study area is a conductive zone due to the distribution of leachate around the landfill. The fluid flow pattern from the isopotential contour shows that the leachate flow leads to the western part of the landfill. The calculation results of the inclined plate model on the AA' and BB' profile shows that the SP anomaly is located at h of 6,59 and 3,53 meters, H of 8,10 and 4,34 meter, respectively, with an angle of 28,81⁰. The depth of leachate accumulation in the AA' profile, located in the west, is deeper than the BB' profile. Thus, the direction of leachate flow is from the eastern to the western, following the elevation changes, where there is a Cisadane river in the part of the west. The groundwater quality around the Rawa Kucing landfill indicated that it was feasible for consumption, although several parameters exceeded the allowable standards. The groundwater sampling conducted during the rainy season is considered to cause the degradation of some pollutant concentrations due to dilution.

BIBLIOGRAPHY

- Arisalwadi, M., and Rahmania, 'Mapping Leachate Distribution Based on the Self-Potential Method in Manggar Landfill, Balikpapan Indonesia', in *Journal of Physics: Conference Series* (Palu: IOP Publishing, 2021), MDCCLXIII, 012013 <<https://doi.org/10.1088/1742-6596/1763/1/012013>>
- Gafur, Abdul, Andi Darma Kartini, and Rahman Rahman, 'Studi Kualitas Fisik Kimia Dan Biologis Pada Air Minum Dalam Kemasan Berbagai Merek Yang Beredar Di Kota Makassar Tahun 2016', *HIGIENE: Jurnal Kesehatan Lingkungan*, 3.1 (2017), 37–46 <<https://www.academia.edu/download/88092641/234747925.pdf>>
- Giang, N. V., K. Kochanek, N. T. Vu, and N. B. Duan, 'Landfill Leachate Assessment by Hydrological and Geophysical Data: Case Study NamSon, Hanoi, Vietnam', *Journal of Material Cycles and Waste Management*, 20.3 (2018), 1648–62 <<https://doi.org/10.1007/s10163-018-0732-7>>
- Hadian, Mohamad Sapari Dwi, Undang Mardiana, Oman Abdurahman, and Munib Ikhwatun Iman, 'Sebaran Akuifer Dan Pola Aliran Air Tanah Di Kecamatan Batuceper Dan Kecamatan Benda Kota Tangerang, Propinsi Banten', *Indonesian Journal on Geoscience*, 1.3 (2006), 115–28 <<https://doi.org/10.17014/ijog.vol1no3.20061>>
- Hamzar, Hamzar, Suprpta Suprpta, and Amal Amal, 'Analisis Kualitas Air Tanah Dangkal Untuk Keperluan Air Minum Di Kelurahan Bontonompo Kecamatan Bontonompo Kabupaten Gowa', *Jurnal Environmental Science*, 3.2 (2021), 150–59 <<https://doi.org/10.35580/jes.v3i2.20048>>
- Handoko, Andri Wasis, D Darsono, and D Darmanto, 'Aplikasi Metode Self Potential Untuk Pemetaan Sebaran Lindi Di Wilayah Tempat Pembuangan Akhir (TPA) Putri Cempo Surakarta', *Indonesian Journal of Applied Physics*, 6.1 (2016), 13–22 <<https://doi.org/10.13057/ijap.v6i01.1792>>
- Janani, T., K. Prasanna, and R. Annadurai, 'Impact of Solid Waste Dumping in Pallavaram Dumping Site, India', in *AIP Conference Proceedings*, 2019, MMCXII, 020145–1–020145–49 <<https://doi.org/10.1063/1.5112330>>
- Jubaedah, Neng E., and Wahyudi W. Parnadi, 'Study of Fluid Flow Movement by Using

- Self Potential Data', in *IOP Conference Series: Earth and Environmental Science* (Bandung: IOP Publishing, 2021), DCCCLXXIII, 012082 <<https://doi.org/10.1088/1755-1315/873/1/012082>>
- Kamboj, Nitin, and Mohrana Choudhary, 'Impact of Solid Waste Disposal on Ground Water Quality near Gazipur Dumping Site, Delhi, India', *Journal of Applied and Natural Science*, 5.2 (2013), 306–12 <<https://doi.org/10.31018/jans.v5i2.322>>
- Kemenkes RI, 'Peraturan Menteri Kesehatan Nomor 492/IV/2010 Tentang Persyaratan Kualitas Air Minum' (Menteri Kesehatan Republik Indonesia, 2010)
- Luhukay, Maryo Rifaldo, Rieneke L E Sela, and Papia J C Franklin, 'Analisis Kesesuaian Penggunaan Lahan Permukiman Berbasis (Sig) Sistem Informasi Geografi Di Kecamatan Mapanget Kota Manado', *Spasial*, 6.2 (2019), 271–81 <<https://doi.org/10.35793/sp.v6i2.25309>>
- Nurullita, Ulfa, Rahayu Astuti, and Mohammad Zaenal Arifin, 'Pengaruh Lama Kontak Karbon Aktif Sebagai Media Filter Terhadap Presentase Penurunan Kesadahan CaCO₃ Air Sumur Artetis', *Jurnal Kesehatan Masyarakat Indonesia*, 6.1 (2020), 48–56 <<https://doi.org/10.26714/jkmi.6.1.2010.%25p>>
- Peavy, Howard, *Environmental Engineering*, 7th edn (McGraw-Hill, 1987)
- Podlasek, Anna, Aleksandra Jakimiuk, Magdalena Daria Vaverková, and Eugeniusz Koda, 'Monitoring and Assessment of Groundwater Quality at Landfill Sites: Selected Case Studies of Poland and the Czech Republic', *Sustainability (Switzerland)*, 13.14 (2021), 7769 <<https://doi.org/10.3390/su13147769>>
- Rao, D. Atchuta, and H. V. Ram Babu, 'Quantitative Interpretation of Self-Potential Anomalies Due to Two-Dimensional Sheet-like Bodies.', *Geophysics*, 48.12 (1983), 1659–64 <<https://doi.org/10.1190/1.1441446>>
- Reynolds, John M., Dick Durrant, Tony Moy, Patrick Hutton, and Stephane Dussy, *Introduction to Applied and Environmental Geophysics*, 2nd edn (John Wiley & Sons, Ltd., 2011)
- Salleh, Nur Fatin Dahlia Mat, and Ku Halim Ku Hamid, 'Effect of Rainfall on Aged Landfill Leachate Constituents', in *BEIAC 2013 - 2013 IEEE Business Engineering and Industrial Applications Colloquium* (Langkawi, Malaysia: IEEE, 2013), pp. 257–61 <<https://doi.org/10.1109/BEIAC.2013.6560127>>
- Santoso, Budy, Subagio Subagio, Mia Uswatun Hasanah, and Hilman Suwarga, 'Investigasi Pendugaan Gerakan Tanah Menggunakan Metode Electrical Resistivity Tomography Dan Self Potential Di Daerah Pasanggrahan Baru, Sumedang Selatan', *Jurnal Geologi Dan Sumberdaya Mineral*, 21.1 (2020), 33–44 <<https://doi.org/10.33332/jgsm.geologi.v21i1.497>>
- Sawyer, Henry Olawale, Adedotun Timothy Adeolu, Abiodun Segun Afolabi, Oluwatoyosi Olalekan Salami, and Biola Kazeem Badmos, 'Impact of Dumpsites on the Quality of Soil and Groundwater in Satellite Towns of the Federal Capital Territory, Abuja, Nigeria', *Journal of Health and Pollution*, 7.14 (2017), 15–22 <<https://doi.org/10.5696/2156-9614-7.14.15>>
- Scott, David W., 'Sturges' Rule', *Wiley Interdisciplinary Reviews: Computational Statistics*, 1.3 (2009), 303–6 <<https://doi.org/10.1002/wics.35>>

- Siddiqi, Sajjad Ahmad, Abdullah Al-Mamun, Ahmad Sana, Mahad Said Baawain, and Mahbuboor Rahman Choudhury, 'Characterization and Pollution Potential of Leachate from Urban Landfills during Dry and Wet Periods in Arid Regions', *Water Supply*, 22.3 (2022), 3462–83 <<https://doi.org/10.2166/WS.2021.392>>
- Talalaj, Izabela A., 'Assessment of Groundwater Quality near the Landfill Site Using the Modified Water Quality Index', *Environmental Monitoring and Assessment*, 186.6 (2014), 3673–83 <<https://doi.org/10.1007/s10661-014-3649-1>>
- Telford, W. M., L. P. Geldart, and R. E. Sheriff, *Applied Geophysics*, 1st edn (New York: Cambridge University Press, 1990) <<https://doi.org/10.1017/cbo9781139167932>>
- Touzani, Meryem, Ismail Mohsine, Jamila Ouardi, Ilias Kacimi, Moad Morarech, Mohamed Habib El Bahajji, and others, 'Mapping the Pollution Plume Using the Self-Potential Geophysical Method: Case of Oum Azza Landfill, Rabat, Morocco', *Water (Switzerland)*, 13.7 (2021), 961 <<https://doi.org/10.3390/w13070961>>
- Vaverková, Magdalena Daria, Jakub Elbl, Eugeniusz Koda, Dana Adamcová, Ayla Bilgin, Vojtěch Lukas, and others, 'Chemical Composition and Hazardous Effects of Leachate from the Active Municipal Solid Waste Landfill Surrounded by Farmlands', *Sustainability (Switzerland)*, 12.11 (2020), 4531 <<https://doi.org/10.3390/su12114531>>
- Wahyuni, Wahyuni, Supriyono Eko Wardoyo, and Ridha Arizal, 'Kualitas Air Sumur Masyarakat Di Sekitar Tempat Pembuangan Akhir Sampah (TPAS) Rawa Kucing Kota Tangerang', *Jurnal Sains Natural Universitas Nusa Bangsa*, 7.2 (2017), 68–82 <<https://doi.org/10.31938/jsn.v7i2.256>>
- Yazdani, M, M Monavari, G A Omrani, M Shariat, and M Hosseini, 'Municipal Solid Waste Open Dumping, Implication for Land Degradation', *Solid Earth Discussions*, 7 (2015), 1097–1118 <<https://doi.org/10.5194/sed-7-1097-2015>>