

Financial Ratio and Return on Asset in Mining Companies: Mediating Effect of Firm Size

157

*M Rizzi, Anggraeni Yunita, Sumiyati, Julia Saputra
Universitas Bangka Belitung, Indonesia

Article Info:

Received 09 May 2023

Revised 19 July 2023

Accepted 14 September 2023

ABSTRACT

This research aims to examine the effect of current ratio, debt to equity ratio and total asset turnover on return on assets with firm size as an intervening variable. The population of this study are mining companies listed on the Indonesia Stock Exchange in 2019-2021. The number of observations in this study was 66. The data analysis technique uses path analysis. This study found that current ratio and total asset turnover have a significant positive effect on return on assets, while the debt to equity ratio variable has no effect on return on assets. This study also found that firm size is able to mediate the relationship between debt to equity ratio and return on assets, but is unable to mediate the relationship between current ratio and total asset turnover on return on assets. This finding has implications for a consequence, namely that company size is one of the considerations in managing the rate of return on investment on company assets.

DOI:

[10.21107/jaffa.v11i2.19981](https://doi.org/10.21107/jaffa.v11i2.19981)

ISSN (Online):

2461-0607

ABSTRAK

Penelitian ini bertujuan untuk menguji pengaruh current ratio, debt to equity ratio dan total asset turn over terhadap return on asset dengan firm size sebagai variabel intervening. Populasi penelitian ini adalah perusahaan pertambangan yang terdaftar di Bursa Efek Indonesia pada tahun 2019-2021. Jumlah observasi penelitian ini sebanyak 66. Teknik analisis data menggunakan analisis jalur (path analysis). Penelitian ini menemukan current ratio dan total asset turnover berpengaruh positif signifikan terhadap return on asset, sedangkan variabel debt to equity ratio tidak berpengaruh terhadap return on asset. Penelitian ini juga menemukan firm size mampu memediasi hubungan debt to equity ratio terhadap return on asset, tetapi tidak mampu memediasi hubungan current ratio dan total asset turnover terhadap return on asset. Temuan ini berimplikasi pada sebuah konsekuensi yaitu ukuran perusahaan dijadikan salah satu pertimbangan dalam mengelola tingkat pengembalian investasi terhadap aset perusahaan.

Page:

157-173



This article is published
under the Creative
Commons Attribution
(CC BY 4.0) licence

Keyword:

Current Ratio, Debt to Equity Ratio, Return on Assets, Firm Size

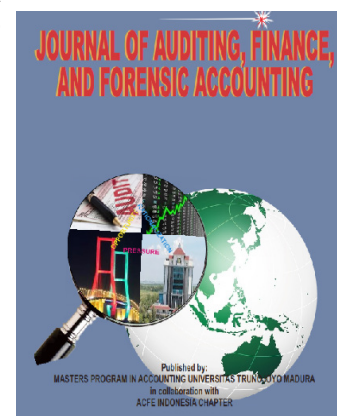

1. INTRODUCTION

The growing competitive advantage requires companies to win business competition. Competitive advantage can create higher economic optimization value for stakeholders (Sunarsih, 2017). This competitive advantage in the context of the company aims to generate optimal profits. In essence, a company is established to generate maximum profit (Harjito & Martono, 2010). Increased competition in the business world requires companies to improve their performance, especially in financial performance. Financial performance is a description of the financial condition of the company which can be assessed through financial ratio analysis, so that it is known whether the company's condition is good or bad which can reflect performance performance in a certain period (Saputra, 2017).

This study aims to examine the direct effect of financial ratios, namely current ratio, total asset turnover, debt to equity ratio on return on assets, and further this study also examines Firm size as a mediating variable in the relationship between current ratio, debt to equity ratio, and total asset turnover on return on assets. This ratio is important because it is used to assess the company's financial performance in this study, namely current ratio, debt to equity ratio and total asset turnover. Current ratio is used to assess the ability of a company to pay short-term obligations that are due immediately, a high current ratio in the company can provide good assurance for creditors in view of the company's ability to pay off its short-term obligations. Furthermore, the debt to equity ratio is used to what extent the company uses funding through debt (financial leverage), the higher the debt to equity ratio, the smaller the amount of owner's capital that can be used as collateral for financial leverage. Total asset turnover is used to assess the company's effectiveness in utilizing total asset turnover in generating sales (sales), the higher the company's asset turnover rate, the more efficient it will be and vice versa (Harjito & Martono, 2010).

Previous research is Lely & Maria (2020) stated the result that the current ratio has a significant effect on the company's financial performance. Meanwhile, research conducted Astutik et al. (2019) stated that the current ratio partially has a positive effect and has no significant effect on financial performance. Furthermore, the results of research Kusumawati & Widaryanti (2022) states that the debt to equity ratio shows significant results on financial performance, but is different from the results of the study. Lely & Maria (2020) which states that the debt to equity ratio has no significant effect on financial performance. Then, the results of research Astutik et al. (2019) states that total asset turnover partially has a positive and significant effect on financial performance, as well as the results of research from Rahmawati & Khoiriawati (2022) stated that total asset turnover has a positive and insignificant effect on financial performance. Based on the differences in the results of previous research (gap research), it is the motivation for conducting this research.

Mining companies are one of the industrial sub-sectors listed on the Indonesia Stock Exchange, the development of mining sector companies is considered to be one of the sectors that can survive the macroeconomic conditions in Indonesia, compared to other industrial sector companies listed on the Indonesia Stock Exchange. Shares of mining companies experienced the deepest decline of 2.83 percent among other sectoral indices amid the weakening of the Composite Stock Price Index (JCI) in the first trading session, recorded JCI closed with a correction of 0.59 percent or 37.46 points. Namely, the shares of PT Aneka Tambang Tbk (ANTM) led the weakening of the JCI among other mining index constituent members, this stock fell 6.87 percent so that it experienced an auto reject bottom (ARB). PT Timah Tbk. (TINS) shares also experienced an auto reject down after falling 6.88 percent, followed by PT Vale Indonesia (INCO) shares which fell 3.63 percent and PT Bukit Asam Tbk. (PTBA) corrected by 1.69 percent (Tari, 2021).

Furthermore, in the midst of the performance of mining companies that are heating up, three issuers are still recording net losses until September 2021. However, the losses of two issuers were recorded to have shrunk sharply, including PT Eksploitasi Energi Indonesia Tbk (CNKO) which still recorded a net loss of IDR 75.71 billion in the third quarter of 2021. This amount decreased by 45.72 percent from the same period in the previous year of IDR 139.48 billion. PT Indika Energy Tbk (INDY) also still recorded a net loss of Rp 86.16 billion. However, the total shrank sharply by 91.37 percent compared to the third quarter of 2020 which amounted to Rp 987.31 billion. Meanwhile, PT Borneo Olah Sarana Sukses Tbk (BOSS) scored a loss of IDR 109.17 billion in the third quarter of 2021. This amount increased by 111.63 percent compared to the same period the previous year of IDR 51.58 billion (Cakti, 2022). This research contributes to investors' attention to company size can be one of the considerations in managing the rate of return on investment on company assets.

2. LITERATURE REVIEW AND HYPOTHESIS DEVELOPMENT

Signaling Theory

Signaling theory was first proposed by Spence (1973) and explains that the owner of the information provides a signal or signal in the form of information that reflects the condition of a company that is beneficial to the recipient (investor). Signal theory explains management's perception of the company's future growth, which will affect the response of potential investors to the company (Brigham & Houston, 2011). The signal is in the form of information that explains management's efforts to realize public wishes. This information is considered an important indicator for investors and business people in making investment decisions. Information submitted by the company and received by investors, will be interpreted and analyzed first whether the information is considered a positive signal (good news) or a negative signal (bad news) (Hartono, 2010).

Financial Performance

Financial performance in the context of the business world has a very broad definition. The Indonesian Institute of Accountants (IAI) defines financial performance as the company's ability to manage and control its resources (IAI, 2007). Financial performance is a description of the achievement of the company's success, which can be interpreted as the results that have been achieved for the various activities that have been carried out. It can be explained that financial performance is an analysis carried out to see the extent to which a company has carried out using the rules of financial implementation properly and correctly (Fahmi, 2012). Return on assets is a ratio that shows the results on the number of assets used by the company, this ratio reflects how much return is generated for each rupiah invested in assets. This means that the higher the return on asset results, the better (Mardiyanto, 2018).

Financial Ratios

Financial ratios are financial analysis tools that are often used in analyzing and assessing a company's financial position and condition. In other words, that financial ratios can provide an overview of the company's performance conditions whose financial statements need to be analyzed in order to determine the condition of the company's financial performance. Financial ratio analysis is a number obtained from the comparison of one financial statement item with another item that has a relevant and significant (meaningful) relationship. Financial ratio analysis is one way to assess the company's past and present performance (Harahap, 2018).

Effect of Current Ratio on Return on Asset

Current ratio is the method most often used to analyze the liquidity level of a company. According to Kasmir (2020) current ratio is a ratio used to measure or assess the company's ability to pay its short-term obligations that are due immediately. Subramanyam (2014) explains the current ratio (CR) is a ratio that compares the current assets owned by the company with short-term debt. Lely & Maria (2020) also examines the current ratio which also affects return on assets. Some researchers also produce similar research results (Alpi & Gunawan, 2018; Mahardhika & Marbun, 2016; Utama & Muid, 2014). Herliana (2021) and Firmanza et al. (2021) also found that current ratio affects return on assets. This study uses the current ratio to measure the company's ability to pay short-term obligations or debts that are due immediately by utilizing available current assets. The higher the current ratio, the smoother the company's cash flow and the timely payment of debts or short-term obligations. Because of this, the greater the indication of the company in knowing how the results of its financial performance.

H_1 : Current ratio has a positive effect on return on assets.

Effect of Debt to Equity Ratio on Return on Asset

Debt to Equity Ratio is used to determine the amount of funds provided by creditors to entity or company owners. According to Destiani & Hendriyani (2022) the debt to equity ratio is the return between the debt owned by the company and its own capital. The higher this ratio means that there is less equity capital compared to the debt. For the company, the amount of debt should not exceed its own capital so that the fixed costs are not too high. The use of the debt to equity ratio is to measure the level of debt usage with the company owner's capital or to determine the ratio of the amount of funds provided by the borrower (creditor) to the capital of the company owner. The higher the debt to equity ratio, the lower the company's funding provided by the company owner. Mahardhika & Marbun (2016) found that the debt to equity ratio has a significant effect on return on assets. Likewise, Solihin (2019) and Utama & Muid (2014) found the same thing that the debt to equity ratio has a significant effect on return on assets.

H₂: Debt to equity ratio has a significant effect on return on assets.

Effect of Total Asset Turn Over on Return on Asset

Total Asset turn over is one of the ratios used to analyze the level of company activity. Total asset turn over shows how the company utilizes all its assets in supporting the company to generate profits (Widiyanti, 2019). Total asset turn over is a measure of the effectiveness of asset utilization in generating sales, the greater the asset turnover the more effective the company is in managing its assets (Destiani & Hendriyani, 2022). Furthermore, the use of total asset turn over is to measure the company's ability to generate sales from its total assets by comparing net sales with total assets to achieve profits. The relationship between assets and sales is called asset turnover and measures the company's effectiveness in generating sales using its assets (Kasmir, 2012). The greater this ratio, the better the company's performance, which means that assets can turn faster and achieve profits and show the more efficient use of all assets in generating sales. As previous research by Alpi & Gunawan (2018) found that the debt to equity ratio has a significant effect on return on assets. Muchlis (2017) and Supardi et al. (2016) also found the same thing that the debt to equity ratio affects return on assets.

H₃: Total asset turnover has a significant effect on return on assets.

The Effect of Firm Size Mediating Current Ratio, Debt to Equity Ratio, and Total Assets Turnover on Return on Assets

Firm size is an important factor that influences the results of the company's financial performance. Companies that have a large size have an influence on the company's profit power. According to Agustia & Suryani (2018), company size is a scale where the size and size of the company can be classified in various ways, namely total assets, log size, sales, and market capitalization.

H₄: Firm size mediates the effect of current ratio, debt to equity ratio and total asset turnover on return on assets in mining companies listed on the Indonesia Stock Exchange.

3. RESEARCH METHODS

This type of research is quantitative research. The population in this study are mining companies listed on the Indonesia Stock Exchange, totaling 54 companies. The observation period covers 2019-2021. The sampling method used is purposive sampling with the following criteria:

1. Mining companies listed on the Indonesia Stock Exchange (IDX) consecutively from 2019-2021.
2. Mining companies that consistently publish annual financial reports (annual reports) needed during 2019-2021.
3. Mining companies that did not experience losses during the 2019-2021 research period.

Based on these criteria, the final sample of this study was 22 mining companies with the observation period 2019-2021 (Table 1). So the number of observations in this study was 66 observations.

**Table 1
Research Sample**

No	Company Code	Company Name
1	ADRO	Adaro Energy Tbk.
2	BIPI	Astrindo Nusantara Infrastruktur Tbk.
3	BRMS	Bumi Resources Minerals Tbk.
4	BSSR	Baramulti Suksessarana Tbk.
5	BYAN	Bayan Resources Tbk.
6	DEWA	Darma Henwa Tbk.
7	GEMS	Golden Energy Mines Tbk.
8	MBAP	Mitrabara Adiperdana Tbk.
9	MYOH	Samindo Resources Tbk.
10	PTRO	Petrosea Tbk.
11	TOBA	TBS Energi Utama Tbk.
12	APEX	Apexindo Pratama Duta Tbk.
13	ITMG	Indo Tambangraya Megah Tbk.
14	ELSA	Elnusa Tbk.
15	ENRG	Energi Mega Persada Tbk.
16	RUIS	Radiant Utama Interinsco Tbk.
17	ANTM	Aneka Tambang Tbk.
18	CITA	Mineral Investindo Tbk.
19	IFSH	Ifishdeco Tbk
20	INCO	Vale Indonesia Tbk.
21	MDKA	Merdeka Copper Gold Tbk.
22	ZINC	Kapuas Prima Coal Tbk.

Source: Data processed in 2023

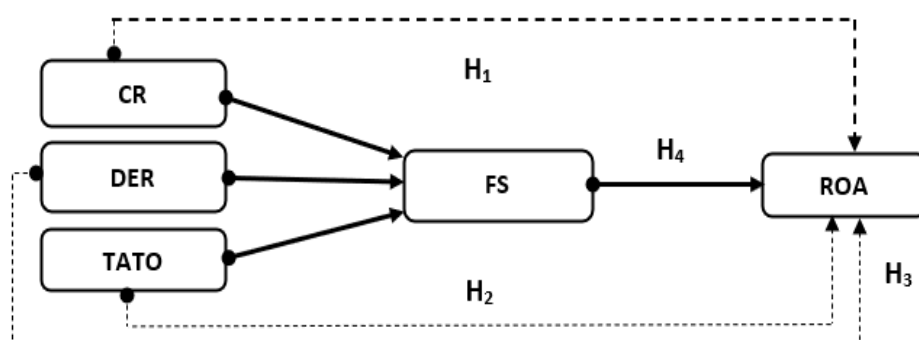

Figure 1

Research Method

Source: Compiled by researchers (2023)

The dependent variable of this study is Return on Asset (ROA). ROA is a measure of financial performance (Mardiyanto, 2018; Wijaya, 2019). ROA is calculated by profit after tax divided by total assets (Kasmir, 2010; Lusy et al., 2018). The independent variables of this study are Current Ratio (CR), Debt to Equity Ratio (DER), and Total Asset Turn Over (TATO). The current ratio (CR) variable measures the company's ability to pay short-term obligations or debts that are due immediately by utilizing available current assets. Current ratio (CR) is calculated by comparing the current assets owned by the company with short-term debt (Lusy et al., 2018; Subramanyam, 2014). The Debt to Equity Ratio (DER) variable measures the ratio of the amount of funds provided by the borrower (creditor) to the capital of the company owner. DER is calculated by the ratio of debt to equity or capital (Kasmir, 2010; Lusy et al., 2018; Agustia & Suryani, 2018).

The Total Asset Turn Over (TATO) variable measures the company's ability to generate sales from its total assets (Destiani & Hendriyani, 2022). TATO is calculated by comparing net sales with total assets to achieve profit. The intervening variable in this study is the firm size variable or Firm Size (FS). Company size is a scale where the size and size of the company can be classified (Agustia & Suryani, 2018). This research model can be seen in Figure 1.

This research conducted several stages of data analysis. First, descriptive statistical analysis. Second, classical assumption tests, which include normality, multicollinearity, heteroscedasticity, and autocorrelation tests. Third, path analysis. Fourth, hypothesis testing.

4. RESULTS AND DISCUSSION

Descriptive Analysis Results

Table 2 shows that the maximum value of the current ratio is 8.28 percent and 0.33 percent as the minimum value with a standard deviation of 1.67170 and an average value of 2.0776. The maximum value of the debt to equity ratio is shown at 7.89 percent and 0.11 percent as the minimum value with a standard deviation of 1.19147 and an average value of 1.0959. The maximum value

Financial Ratio

of total asset turnover is 1.91 times and the lowest value is 0.1 times with a standard deviation of 0.50382 with an average value of 0.7967. The maximum value of firm size reaches 38.09, and the minimum reaches 29.55 with a standard deviation value of 2.66787 and an average value of 34.7564. The maximum value of return on assets is 52.02 percent and a minimum of 0.19 percent with a standard deviation of 11.01354 with an average value of 9.6641.

164**Classical Assumption Testing Results**

The results of the normality test using the one sample kolmogorov-smirnov test phase I show the kolmogorov-smirnov value with residual data asymp.sig (2-tailed) value of 0.002 and this value is below the significant (α) of 0.05, which means that the research data is not normally distributed. Data transformation is carried out on the ROA variable with square root transformation, because the histogram graph form of the ROA variable is moderate positive skewness (Ghozali, 2018). The normality test results after the square root data transformation show the one-sample kolmogorov-smirnov test value with the residual data Asymp.sig (2-tailed) value of 0.200 and this value indicates that the regression equation model is normally distributed.

The VIF test results show that all independent variables have a tolerance value > 0.10 and a VIF value < 10 so it can be concluded that there are no multicollinearity symptoms in this regression model. The results of the heteroscedasticity test on the scatterplot graph show that the points spread randomly and do not form a clear or regular pattern, and are spread both above and below the number 0 on the Y axis. Thus this shows that there is no heteroscedasticity in the regression model or it can be said that the independent variables do not occur heteroscedasticity. The Durbin-Watson autocorrelation test results show that the Durbin-Watson value is 1.498, so it can be concluded that there is no autocorrelation because the D-W value is between $-2 < (1.498) > +2$.

Table 2
Descriptive Statistics

	N	Minimum	Maximum	Mean	Std. Deviation
CR	66	,33	8,28	2,0776	1,67170
DER	66	,11	7,89	1,0959	1,19147
TATO	66	,01	1,91	,7967	,50382
ROA	66	,19	52,02	9,6641	11,01354
FS	66	29,55	38,09	34,7564	2,66787
Valid N (listwise)	66				

Source: Data processed in 2023

Tabel 3
Phase I T Test Results Firm Size

Coefficients ^a		
Model	t	Sig
(Constant)	38,514	,000
CR	-,630	,531
DER	1,408	,164
TATO	-1,126	,264

a. Dependent Variable: FS

Source: Data processed in 2023

Tabel 4
Phase II T Test Results Return on Asset

Coefficients ^a			
	Model	t	Sig
1	(Constant)	38,514	,000
	CR	-,630	,531
	DER	1,408	,164
	TATO	-1,126	,264
	FS	3,812	,000

a. Dependent Variable: FS

Source: Data processed in 2023

Hypothesis Testing Results

T Statistical Test

Based on Table 3, it can be seen that the tcount value of CR $-0.630 < t$ table 1.998 and the significance level is $0.531 > 0.05$, it is concluded that partially CR has no significant effect on FS. Then, the tcount value of DER $1.408 < t$ table 1.998 and the significance level is $0.164 > 0.05$, it is concluded that partially DER has no significant effect on FS. And the tcount value of TATO $-1.126 < t$ table 1.998 and the significance level is $0.264 > 0.05$, it is concluded that partially TATO has no significant effect on FS.

Based on Table 4, it can be seen that the tcount value of CR $2.720 > t$ table 1.998 and the significance level of $0.008 < 0.05$, it is concluded that partially CR has a significant positive effect on ROA. Then, the tcount value of DER $-1.055 < t$ table 1.998 and the significance level of $0.296 > 0.05$, it is concluded that partially DER has a negative and insignificant effect on ROA. Furthermore, the tcount value of TATO is $6.103 > t$ table 1.998 and the significance level is $0.000 < 0.05$, it is concluded that partially TATO has a significant positive effect on ROA. And the tcount value of FS $3,812 > t$ table $1,998$ and the significance level of $0.000 < 0.05$, it is concluded that partially FS has a significant positive effect on ROA.

Uji Statistik F

Based on Table 5, it can be seen that the results of the fcount value of CR, DER and TATO on FS $1.691 < f_{table} 2.75$ and a significance level of $0.178 > 0.05$, it is concluded that simultaneously there is no significant effect between the variables CR, DER and TATO on FS.

Based on Table 6, it can be seen that the fcount value of CR, DER, TATO and FS on ROA is $13.912 > F_{table} 2.75$ and the significance level is $0.000 < 0.05$, it is concluded that simultaneously and significantly FS is able to mediate the influence between CR, DER and TATO variables on ROA.

Tabel 5
Phase I F Test Results Firm Size

ANOVA ^a					
Model	Sum of Squares	df	Mean Square	F	Sig.
1 Regression	34,987	3	11,662	1,691	,178 ^b
Residual	427,549	62	6,896		
Total	462,536	65			

a. Dependent Variable: FS

b. Predictors: (Constant), TATO, CR, DER

Source: Data processed in 2023

Tabel 6
Phase II F Test Results Return on Asset

ANOVA ^a					
Model	Sum of Squares	df	Mean Square	F	Sig.
1 Regression	3761,462	4	940,365	13,912	,000 ^b
Residual	4123,160	61	67,593		
Total	7884,622	65			

a. Dependent Variable: ROA

b. Predictors: (Constant), FS, CR, TATO, DER

Source: Data processed in 2023

Tabel 7
Phase I Determinant Coefficient Results Firm Size

Model Summary ^b				
Model	R	R Square	Adjusted R Square	Std. Error of the Estimate
1	,275 ^a	,076	,031	2,62601

a. Predictors: (Constant), TATO, CR, DER

b. Dependent Variable: FS

Source: Data processed in 2023

**Tabel 8
Phase I Determinant Coefficient Results Firm Size**

Model Summary ^b				
Model	R	R Square	Adjusted R Square	Std. Error of the Estimate
1	,691 ^a	,477	,443	8,22148

a. Predictors: (Constant), FS, CR, TATO, DER
b. Dependent Variable: ROA

Source: Data processed in 2023

Uji Koefisien Determinan (R²)

Based on Table 7, it can be seen that the coefficient of determination Adjusted R-Square (R²) is 0.031 or 3.1%, so it can be concluded that the independent variables are able to explain the dependent variable by 3.1%, and the remaining 96.9% is explained by other variables not used in this study.

Based on Table 8, it can be seen that the coefficient of determination Adjusted R-Square (R²) is 0.443 or 44.3%, so it can be concluded that the independent variables are able to explain the dependent variable by 44.3%, and the remaining 55.7% is explained by other variables not used in this study.

Path Analysis

Based on Figure 2 path analysis diagram, it can be seen that the direct effect value of CR on ROA is 0.228. The direct effect of DER on ROA is -0.038. Furthermore, the direct effect of TATO on ROA is 0.538. And the direct effect of FS on ROA is 0.524. Indirect effect (mediation) of CR, DER and TATO on ROA through FS is:

Current ratio : $-0,197 \times 0,524 = -0,103$
Debt to equity ratio : $0,200 \times 0,524 = 0,105$
Total asset turn over : $-0,424 \times 0,524 = -0,222$

The direct effect of CR on ROA is 0.228 while the indirect effect of CR to ROA through FS is -0.103, so it is concluded that CR has a direct effect on ROA and FS is not an intervening variable. Furthermore, the direct effect of DER on ROA is -0.038 while the indirect effect of DER to ROA through FS is 0.105, it is concluded that DER has an indirect effect on ROA and FS is an intervening variable. And the direct effect of TATO on ROA is 0.538 while the indirect effect of TATO to ROA through FS is -0.222, it is concluded that TATO has a direct effect on ROA and FS is not an intervening variable.

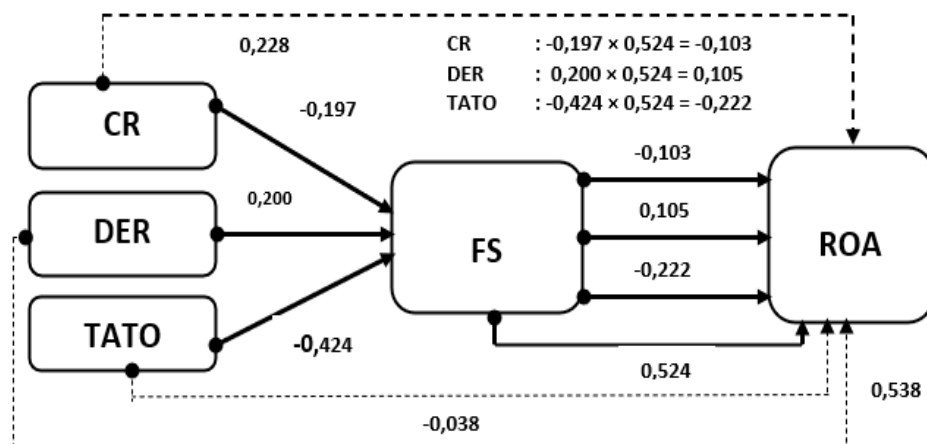

Figure 2
Path Analysis Diagram

Discussion

Effect of Current Ratio on Return on Assets

The statistical test results show that the current ratio affects the return on assets. Current ratio according to its characteristics is part of the liquidity ratio which aims to measure the ability of a company to meet its short-term obligations (Ang, 1997). The higher the current ratio of a company means the smaller the risk of the company's failure to meet its short-term obligations. As a result, the risk that will be borne by shareholders is also getting smaller (Ang, 1997). A high current ratio can have an impact on the company being able to more freely use its current assets to fund the company's operations so as to facilitate the company's activities in optimizing profits. Indirectly, it will be able to increase the level of return ratio compared to the company's assets. The results of this study support previous research conducted by several researchers that current ratio affects return on assets (Alpi & Gunawan, 2018; Lely & Maria, 2020; Mahardhika & Marbun, 2016; Utama & Muid, 2014).

Effect of Debt to Equity Ratio on Return on Assets

The statistical test results on the debt to equity ratio variable have no significant effect on return on assets. This result contradicts the theory that the funding policy reflected in the debt equity ratio (DER) greatly affects the achievement of profits earned by the company. Ang (1997) states that the higher the DER will affect the amount of profit (return on assets) achieved by the company. The higher the DER shows the greater the trust from outsiders, this is very likely to improve the company's performance, because with large capital, the opportunity to achieve a large level of profit is also great. Therefore, in theory, the effect of DER on ROA is positive, which is contrary to the results of this study. This is because in the context of mining companies, the high and low leverage of the company is not solely caused by management performance, but also influenced by other factors so that DER may have less impact on the achievement of company profits.

The results of this study do not support previous research conducted by several researchers that the debt to equity ratio affects return on assets (Mahardhika & Marbun, 2016; Solihin, 2019; Utama & Muid, 2014). This study supports research that has been conducted by Supriantikasari & Utami, (2019) and Puspitadewi & Rahyuda (2016).

Effect of Total Assets Turnover on Return on Assets

The statistical test results show that total assets turnover has an effect on return on assets. This is because the low Return on Assets (ROA) is due to low profit margins due to low asset turnover. The relationship between assets and sales is called asset turnover and measures the effectiveness of the company to generate sales using its assets (Kasmir, 2012). So the greater this ratio the better, which means that assets can turn faster and achieve profits and show the more efficient use of overall assets in generating sales. The results of this study support previous research conducted by Alpi & Gunawan (2018), Muchlis (2017), and Supardi et al. (2016) that debt to equity ratio affects return on assets.

Mediating Effect of Firm Size on Current Ratio, Debt to Equity Ratio, and Total Asset Turnover on Return on Assets

This study found that firm size is able to mediate the relationship between debt to equity ratio, while for the relationship between current ratio and total asset turnover to ROA, firm size has not been able to mediate the relationship. According to Agustia & Suryani (2018), company size is a scale where the size and size of the company can be classified in various ways, namely total assets, log size, sales, and market capitalization. This indicates that the larger the size of the company, it can trigger the amount of company leverage which has an impact on increasing ROA or company profits. On the other hand, company size does not necessarily trigger the relationship between the company's current ratio and the achievement of the company's ROA. So the size of the company does not directly trigger the improvement of the company's current ratio and ROA.

5. CONCLUSIONS AND SUGGESTIONS

This study aims to examine the factors that affect financial performance (ROA) in terms of current ratio, debt to equity ratio and total asset turnover by using firm size as an intervening variable. This study found that current ratio and total asset turnover have a positive and significant effect on return on assets while debt to equity ratio has no effect on ROA. This study also found that firm size is able to mediate the relationship between debt to equity ratio, while for the relationship between current ratio and total asset turnover to ROA, firm size has not been able to mediate the relationship.

The implication of this research is that companies should pay more attention to their debt ratio, especially their short-term debt or liabilities. Companies pay more attention to the level of

sales or the level of company assets, look for ways to make asset turnover faster and pay more attention to the management of funds or assets embedded in the company. For investors, if the company is able to overcome its short-term obligations, it means that there is no problem in liquidating the company. This will increase investor confidence in investing which has an impact on improving the company's financial performance.

REFERENCES

- Agustia, Y. P., & Suryani, E. (2018). Pengaruh Ukuran Perusahaan, Umur Perusahaan, Leverage, dan Profitabilitas terhadap Manajemen Laba (Studi pada Perusahaan Pertambangan yang Terdaftar di Bursa Efek Indonesia Periode 2014-2016). *Jurnal Aset (Akuntansi Aset)*, 10(1), 63–74. <https://ejournal.upi.edu/index.php/aset/article/download/12571/7503>
- Alpi, M. F., & Gunawan, A. (2018). Pengaruh Current Ratio dan Total Assets Turnover terhadap Return on Assets pada Perusahaan Plastik dan Kemasan. *Aksioma: Jurnal Riset Akuntansi*, 17(2), 1–36. <http://www.aksioma.unram.ac.id/index.php/aksioma/article/view/43/34>
- Ang, R. (1997). *Buku Pintar Pasar Modal Indonesia (First Edition)*. Jakarta: Mediasoft Indonesia.
- Astutik, E. P., Retnosari, R., Nilasari, A. P., & Hutajulu, D. M. (2019). Analisis Pengaruh Rasio Likuiditas, Solvabilitas dan Profitabilitas terhadap Kinerja Keuangan Perusahaan Manufaktur. *Prosiding Seminar Nasional Fakultas Ekonomi Untidar, Magelang*, Selasa, 15 Oktober 2019.
- Brigham, E. F., & Houston, J. F. (2011). *Essentials of Financial Management*. (Edisi 11 B). Jakarta: Salemba Empat.
- Cakti, G. A. (2022). *Membaranya Kinerja Emiten Batu Bara*. Dataindonesia.id. <https://dataindonesia.id/bursa-keuangan/detail/membaranya-kinerja-emiten-batu-bara/>
- Destiani, T., & Hendriyani, R. M. (2022). Analisis Rasio Keuangan untuk Menilai Kinerja Keuangan Perusahaan: Studi Kasus pada PT Unilever Indonesia Tbk Tahun 2016-2020. *Al-Kharaj: Jurnal Ekonomi, Keuangan, & Bisnis Syariah*, 4(1), 136–154. <https://doi.org/10.47467/alkharaj.v4i1.488>
- Fahmi, I. (2012). *Analisis Kinerja Keuangan*. Bandung: Alfabeta.
- Firmanza, Nardi, Fathir, K., & Saddam, M. (2021). Pengaruh Current Ratio dan Cash Ratio terhadap Return on Asset pada PT. Sumber Alfaria Trijaya, Tbk di Jakarta Periode Tahun 2012-2019. *Jurnal Neraca Peradaban*, 1(3), 246–254. <https://doi.org/https://doi.org/10.55182/jnp.v1i3.63>
- Ghozali, I. (2018). *Aplikasi Analisis Multivariate dengan Program IBM SPSS 22*. Semarang: Badan Penerbit Universitas Diponegoro.
- Harahap, S. S. (2018). *Analisis Kritis atas Laporan Keuangan*. Jawa Barat: PT Raja Grafindo Persada.

-
- Harjito, A., & Martono. (2010). *Manajemen Keuangan*. Yogyakarta: Ekonesia.
- Hartono, J. (2010). *Teori Portofolio dan Analisis Investasi (Edisi Ketujuh)*. Yogyakarta: BPFEE.
- Herliana, D. (2021). Pengaruh Current Ratio dan Debt to Equity Ratio terhadap Return on Assets pada Perusahaan Pertambangan Sub Sektor Batubara yang Terdaftar di BEI Tahun 2016-2018. *Jurnal Ilmiah Mahasiswa Akuntansi*, 1(1), 1-17. <https://jom.universitassuryadarma.ac.id/index.php/jima/article/view/22/23>
- IAI, I. A. I. (2007). *Standar Akuntansi Keuangan*. Jakarta: Salemba Empat.
- Kasmir. (2010). *Pengantar Manajemen Keuangan*. Jakarta: Kencana.
- Kasmir. (2012). *Analisis Laporan Keuangan (Cetakan ke)*. Jawa Barat: PT Raja Grafindo Persada.
- Kasmir. (2020). *Analisis Laporan Keuangan (Cetakan Ke)*. Jawa Barat: PT Raja Grafindo Persada.
- Kusumawati, E., & Widaryanti. (2022). Analisis Pengaruh Debt to Equity Ratio, Current Ratio, dan Total Aset Turnover terhadap Kinerja Keuangan (Studi Kasus pada Perusahaan Property dan Real Estate yang Terdaftar di BEI Tahun 2015-2020). *Jurnal Ilmiah Fokus Ekonomi, Manajemen, Bisnis & Akuntansi (EMBA)*, 1(2), 227-234. <https://ejournal.stiepena.ac.id/index.php/fokusemba/article/view/513>
- Lely, D., & Maria, S. O. (2020). Pengaruh Likuiditas, Solvabilitas, Manajemen Aset dan Ukuran Perusahaan terhadap Kinerja Keuangan pada Perusahaan Manufaktur yang Terdaftar di BEI Periode 2015-2018. *Jurnal Akuntansi Kontemporer (JAKO)*, 12(1), 20-34. <http://jurnal.wima.ac.id/index.php/JAKO/article/view/2282>
- Lusy, Y. B. H., Panjaitan, T. W. S., & Widyastuti, M. (2018). Effects of Current Ratio and Debt-to-Equity Ratio on Return on Asset and Return on Equity. *International Journal of Business and Management Invention*, 7(12), 31-39.
- Mahardhika, & Marbun, D. (2016). Pengaruh Current Ratio dan Debt to Equity Ratio terhadap Return on Assets. *Widyakala Journal: Jurnal of Pembangunan Jaya University*, 3, 23-28. https://mail.ojs.upj.ac.id/index.php/journal_widya/article/view/21
- Mardiyanto, H. (2018). *Intisari Manajemen Keuangan: Teori, Soal, dan Jawaban*. Jakarta: Grasindo.
- Muchlis, R. R. (2017). Pengaruh Current Ratio, Total Asset Turnover, dan Debt to Asset Ratio terhadap Return on Asset pada Perusahaan Plastik dan Kemasan yang Terdaftar di Bursa Efek Indonesia Periode 2011-2015. Universitas Muhammadiyah Sumatera Utara. <http://repository.umsu.ac.id/handle/123456789/11588>

- Puspitadewi, C., & Rahyuda, H. (2016). Pengaruh DER, ROA, PER, dan EVA terhadap Return Saham pada Perusahaan Food and Beverage di BEI. *E-Jurnal Manajmeen Unud*, 5(3), 1429–1456.
- Rahmawati, M. A., & Khoiriawati, N. (2022). Pengaruh Rasio Likuiditas, Rasio Profitabilitas dan Rasio Aktivitas terhadap Kinerja Keuangan Perusahaan Sektor Keuangan yang Terdaftar di BEI. *Jurnal Ekonomika*, 7(1), 275–285.
- Saputra, R. & Syarfan, La Ode. (2017). Analisis Kinerja Keuangan pada Koperasi Tirta Dharma Perusahaan Daerah Air Minum Kota Pekanbaru. *VALUTA Jurnal Administrasi Bisnis, Manajemen dan Ekonomi*, 3(2), 290–303.
- Solihin, D. (2019). Pengaruh Current Ratio dan Debt to Equity Ratio terhadap Return on Asset. *KREATIF: Jurnal Ilmiah Prodi Manajemen Universitas Pamulang*, 7(1), 115–122.
- Spence, M. (1973). Job Market Signaling. *Quarterly Journal of Economics*, 87(3), 355–374.
- Subramanyam, K. R. (2014). *Financial Statement Analysis (Eleventh Edition)*. Amerika Serikat: Mc Graw Hill.
- Sunarsih, N. (2017). Membangun Keunggulan Kompetitif melalui Inovasi dan Kewirausahaan. In Kewirausahaan dalam Multi Perspektif. Universitas Terbuka, Tangerang Selatan, 43-58. ISBN 978-602-392-156-0. Repository UT. <http://repository.ut.ac.id/7036/1/fe2017-04-nenah.pdf>
- Supardi, H., Sunarto, & Suyanto. (2016). Pengaruh Current Ratio, Debt to Asset Ratio, Total Asset Turnover dan Inflasi terhadap Return on Asset. *JIAFE: Jurnal Ilmiah Akuntansi Fakultas Ekonomi*, 2(2), 16–27. <https://doi.org/https://doi.org/10.34204/jiafe.v2i2.541>
- Supriantikasari, N., & Utami, E. S. (2019). Pengaruh Return on Assets, Debt to Equity Ratio, Current Ratio, Earning Per Share dan Nilai Tukar terhadap Return Saham (Studi Kasus pada Perusahaan Go Public Sektor Barang Konsumsi yang Listing di Bursa Efek Indonesia Periode 2015-2017). *Jurnal Riset Akuntansi Mercubuana*, 5(1), 49–66. <https://doi.org/https://doi.org/10.26486/jramb.v5i1.814>
- Tari, D. N. (2021). *IHSG Koreksi, Saham Sektor Pertambangan Boncos 2,8 Persen*. *Bisnis.Com*. <https://market.bisnis.com/read/20210119/7/1344806/ihsg-koreksi-saham-sektor-pertambangan-boncos-28-persen/>
- Utama, A. C., & Muid, A. (2014). Pengaruh Current Ratio, Debt Equity Ratio, Debt Asset Ratio, dan Perputaran Modal Kerja terhadap Return on Asset pada Perusahaan Manufaktur yang Terdaftar di Bursa Efek Indonesia Tahun 2010-2012. *Diponegoro Journal of Accounting*, 3(2), 1-13.
- Widiyanti, M. (2019). Pengaruh Net Profit Margin, Return on Assets dan Debt To Equity Ratio terhadap Pertumbuhan Laba pada Perusahaan LQ45. *Jurnal Riset Akuntansi dan Keuangan*, 7(3), 545–554.

Wijaya, R. (2019). Analisis Perkembangan Return on Assets (ROA) dan Return on Equity (ROE) untuk Mengukur Kinerja Keuangan. *Jurnal Ilmu Manajemen*, 9(1), 40–51. https://jurnal.um-palembang.ac.id/ilmu_manajemen/article/view/2115/1690

**Journal of
Auditing,
Finance, and
Forensic
Accounting**

***Coressponding Authors:**

Author can be contacted on E-mail: akhmadrizi13@gmail.com

**Volume 11,
Issue 2**